



**NEW** 

 **FOLLOW ME SM**

TRACKLESS TWINNED TELESCOPIC  
CANTILEVER HARDWARE  
SPACE-SAVING FEATURE

FOLLOW ME 5.5		
	mm; kg	mm; kg
A	5000	5500
max. weight gate backspace	500 kg	525 kg
	4930	5330
B	1600	1750
C	2300	2450
D	350	350
G	3915	4290
H	4830	5230
J	370	370
K	645	770
L	7400	8050



FAST,  
DOUBLES SPEED  
OF OPENING



SPACE SAVING FEATURE  
- 36% OF TAILGATE  
SPACE



EASY  
ASSEMBLING



TWIN «C» TRACK  
CANTILEVER SYSTEM



3  
AXIS

2ND CANTILEVER LEAF  
ADJUSTABLE IN 3 AXIS

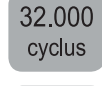

32.000  
cyclus

32.000 CYCLES  
PROVEN & TESTED



270  
g/m<sup>2</sup>

HOT DIPPED  
GALVANIZED



+ 50°C  
TESTED & PROVEN



- 37°C  
TESTED AND PROVEN



SLOTTED HOLE  
PUNCHED EVERY  
400mm IN TRACK



GALVANIZED  
INTERNAL EDGES



«C» TRACK SERIAL NO.  
100% COMPATIBILITY  
CARRIAGE TESTED



GERMAN  
STEEL



15 + 15 BOLTS  
15 + 15 RIVET NUTS  
INCLUDED



C 2  
HIGH QUALITY  
BEARINGS



CARRIAGES CENTER  
HOLES MILLED  
NOT LASER CUT



MULTI RIVETED  
SECTIONS



JAPANESE ROBOTICS  
FANUC



UNIVERSITY OF  
TECHNOLOGY – BRNO



MADE IN  
CZECH REPUBLIC

Valid for gate frame 60x60

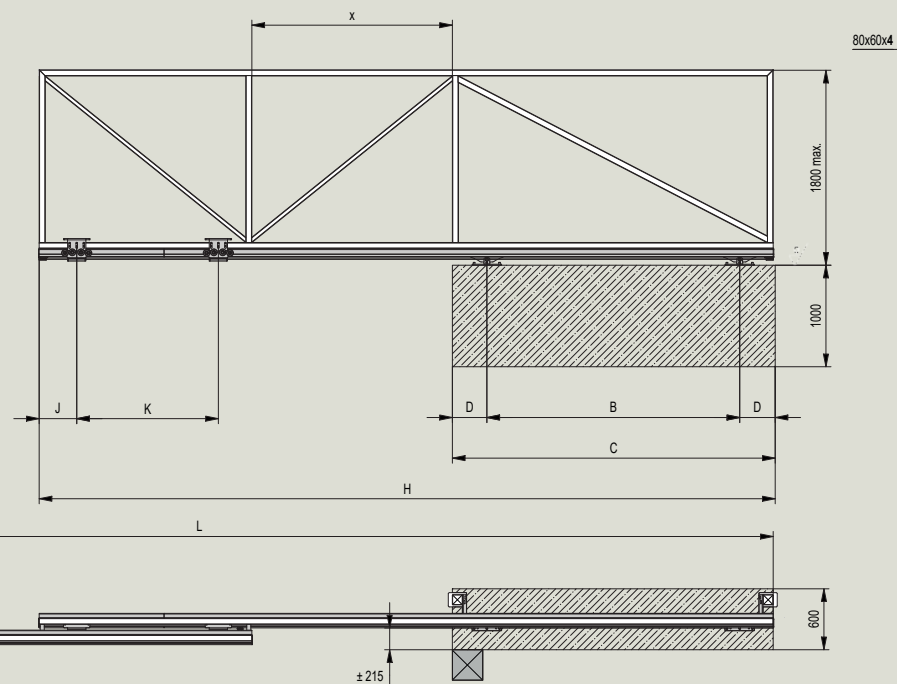
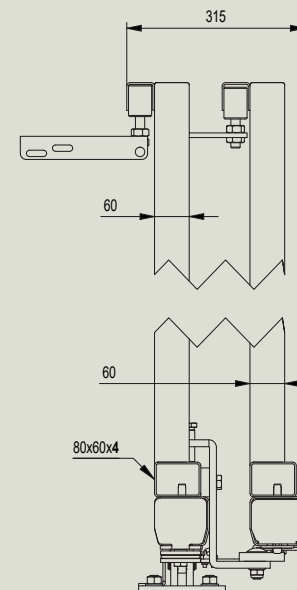
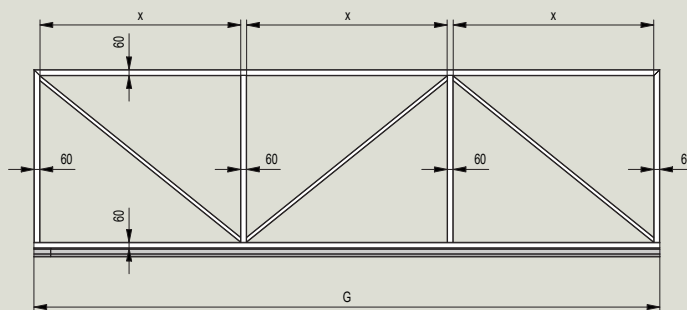

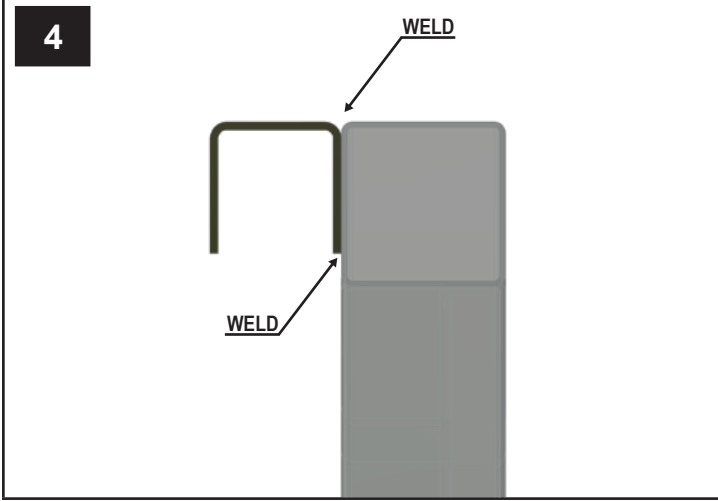
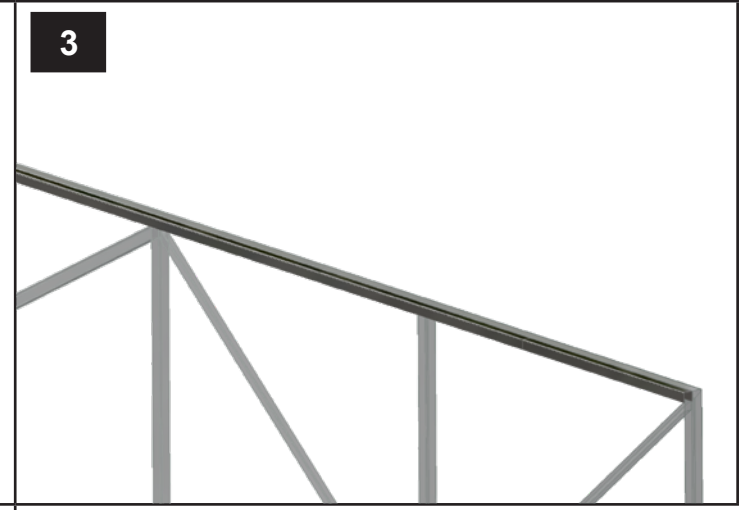
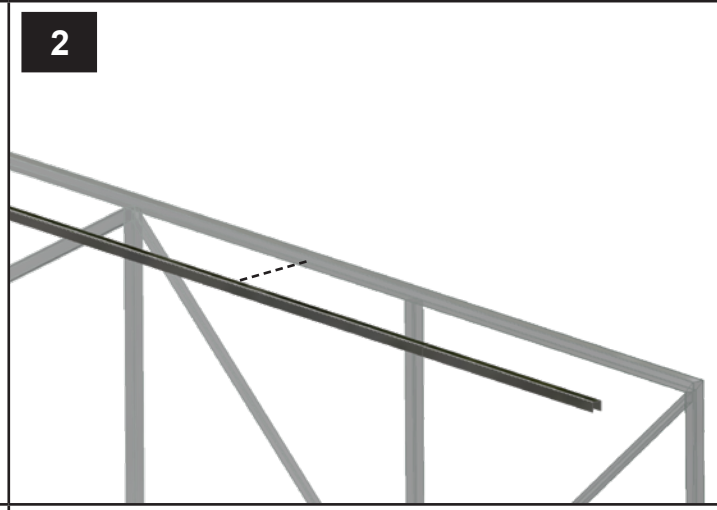
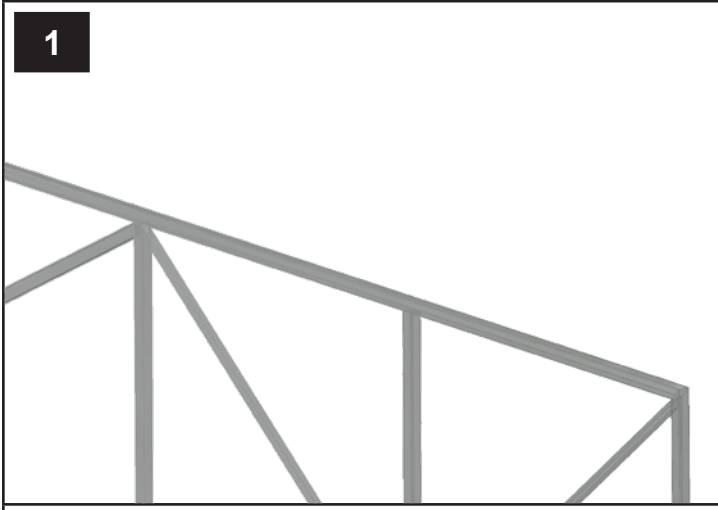

6

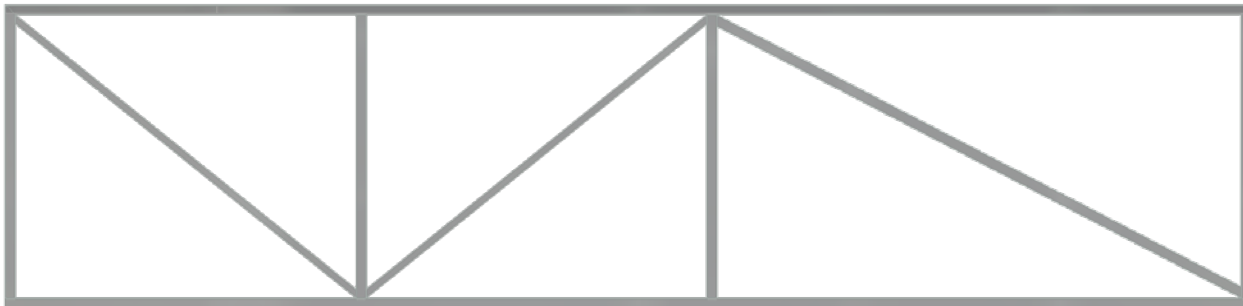

7

RIVET BOLT  
M10x25

BOLT M10x25

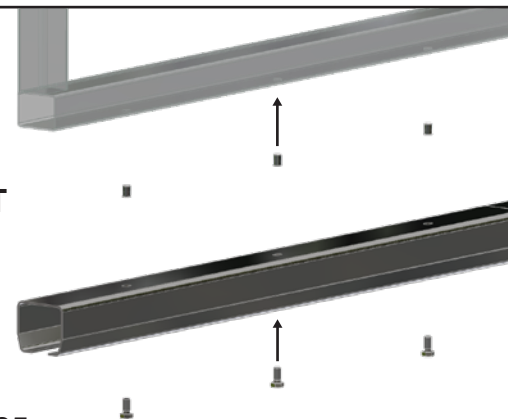

8

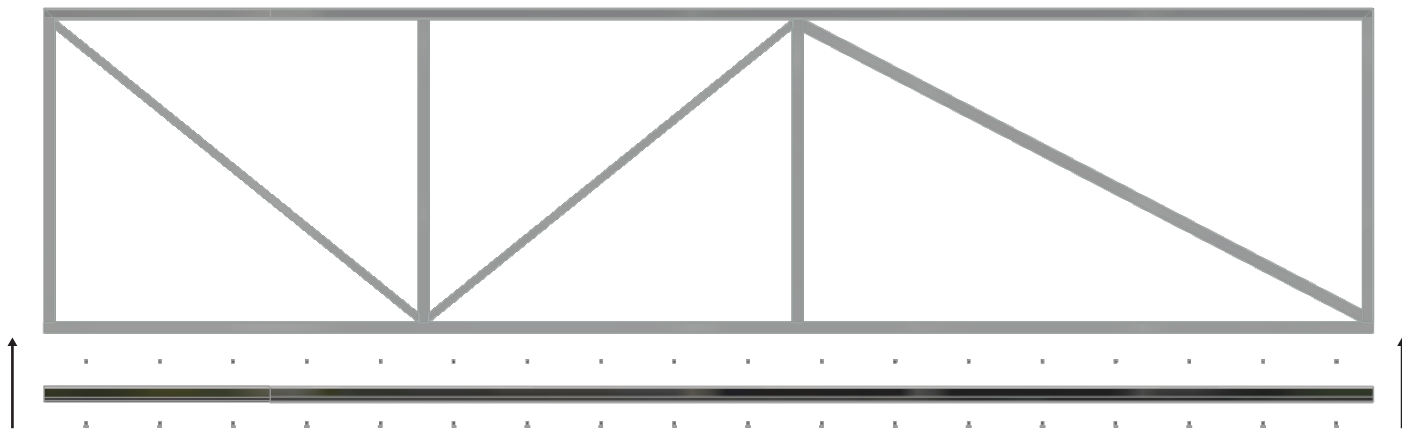

9

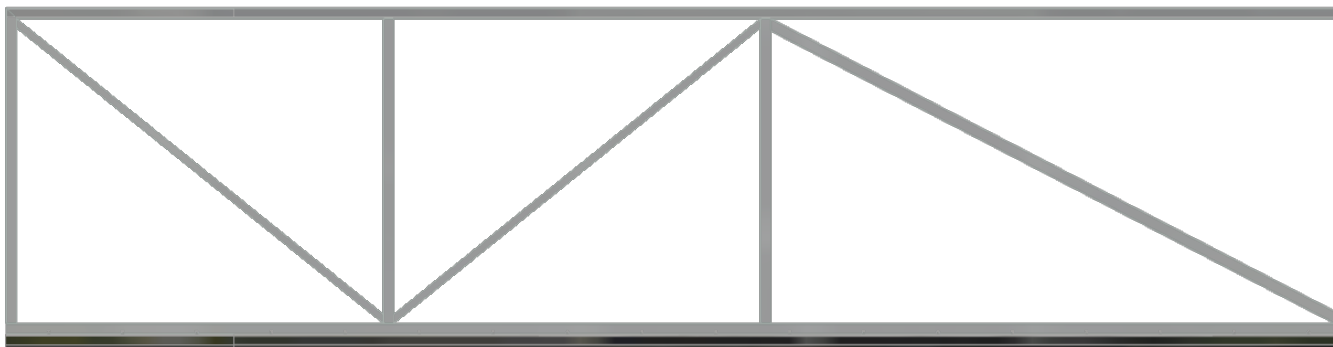



10

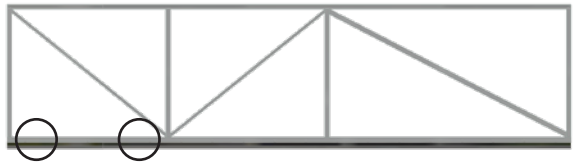

11

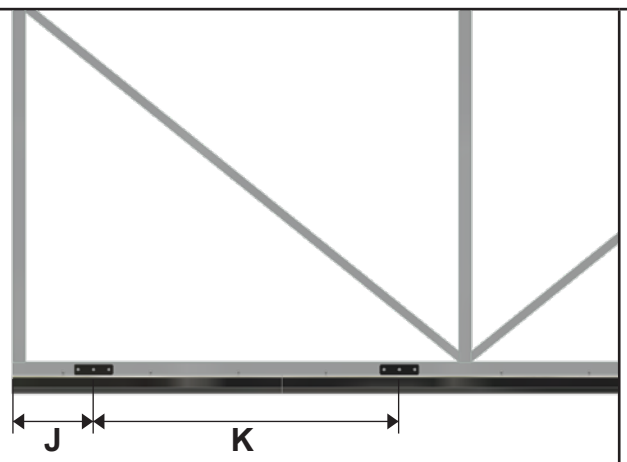

12

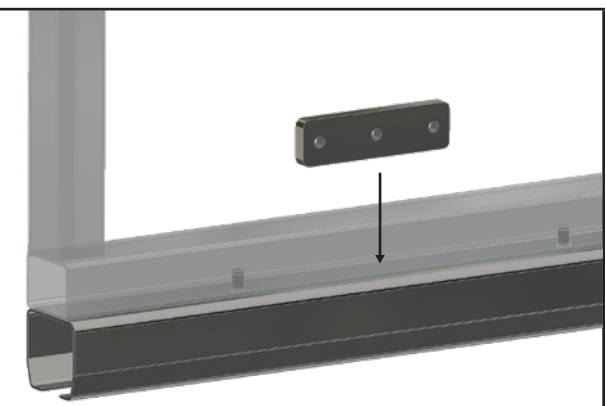

13

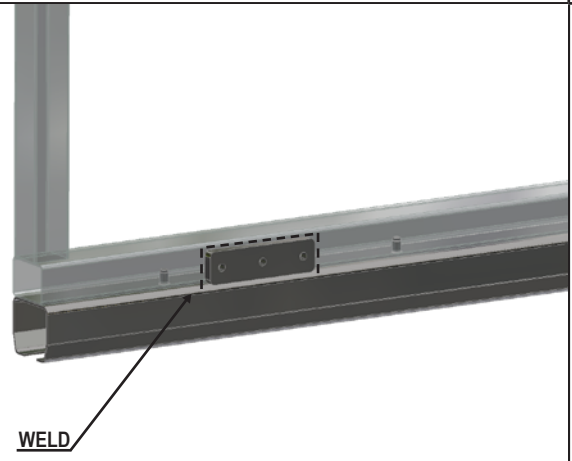

14

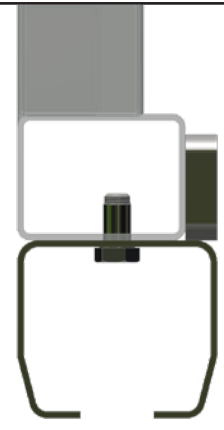

15

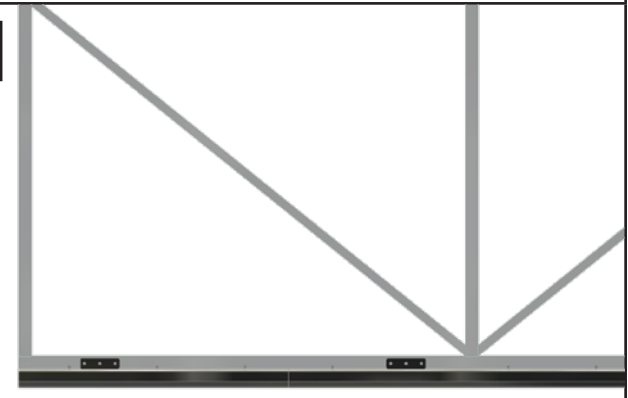

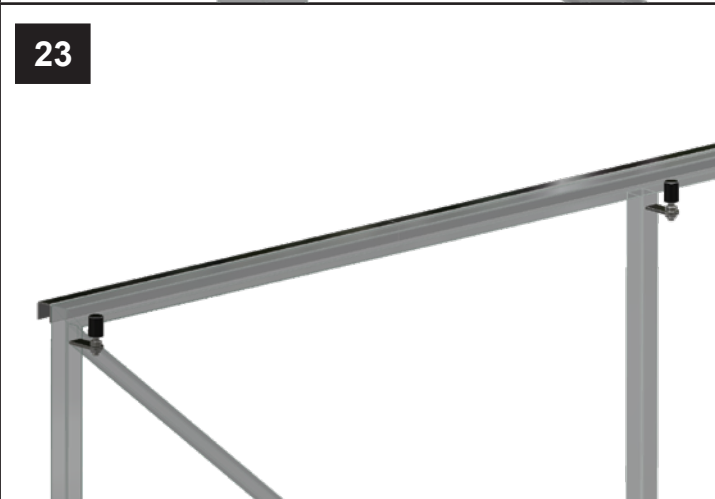
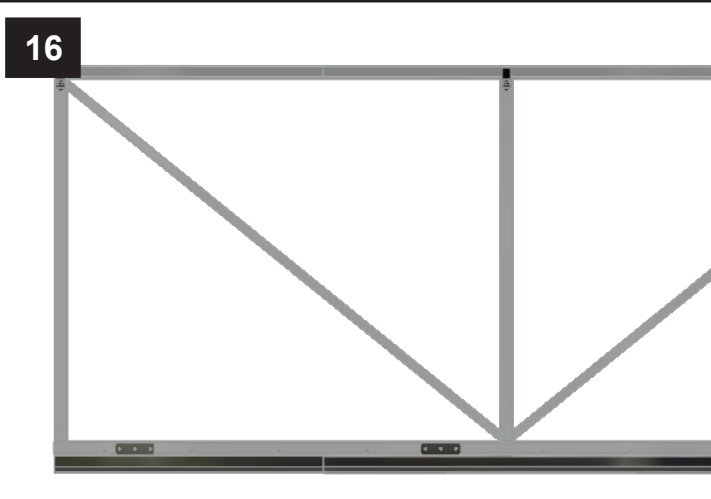

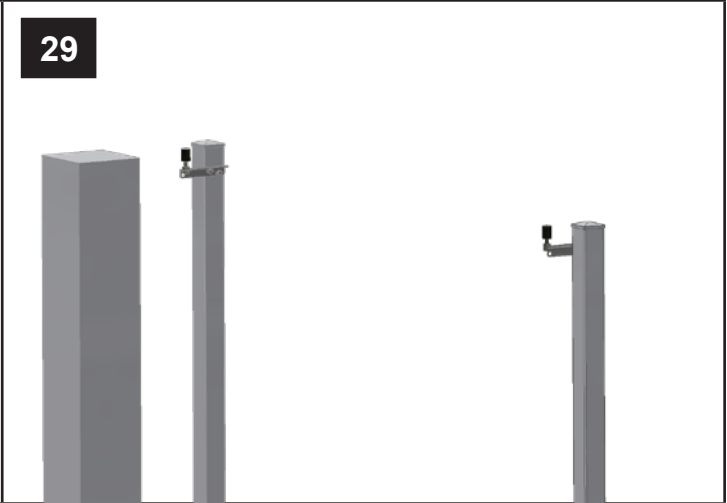
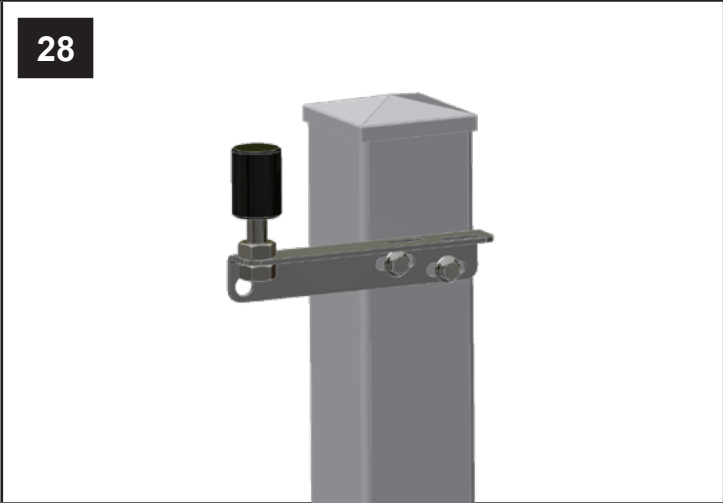
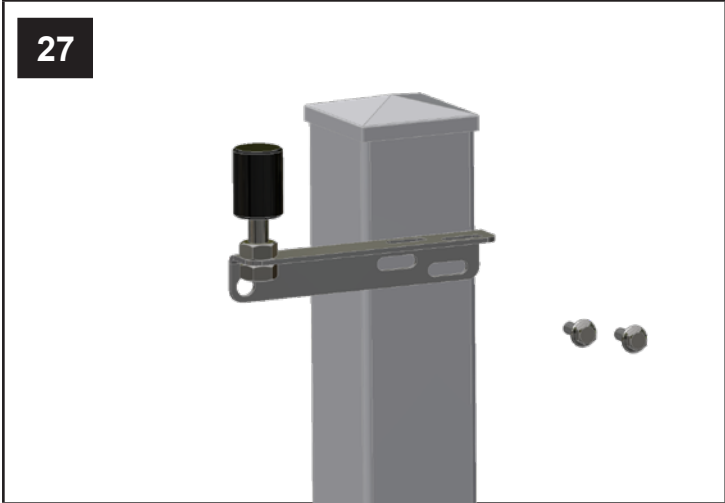
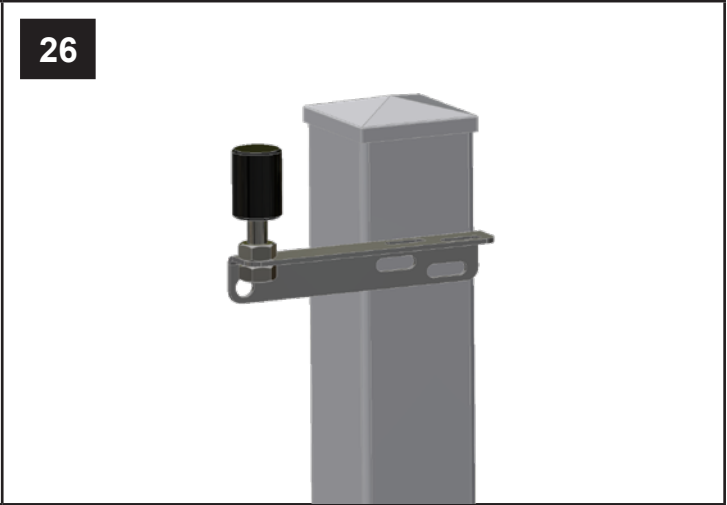
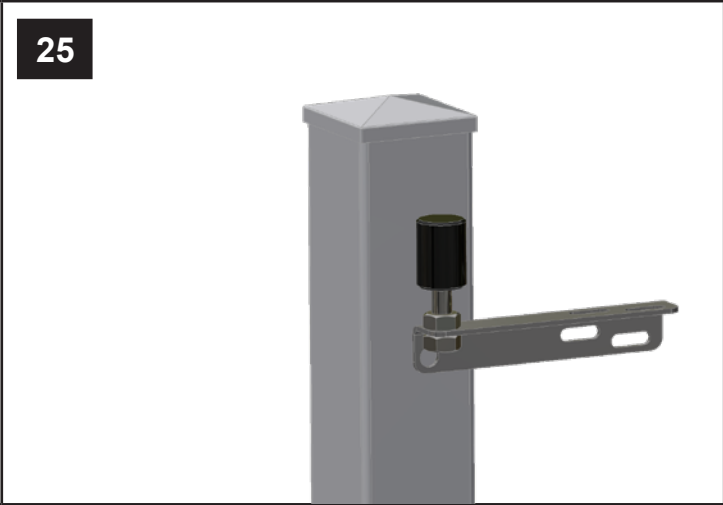
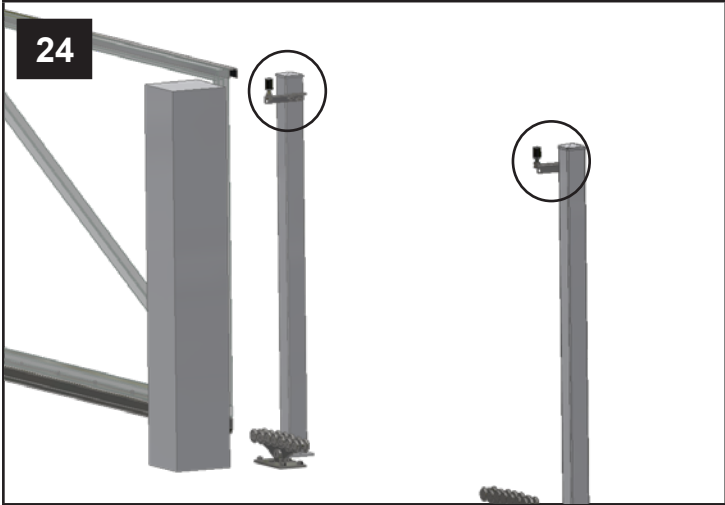

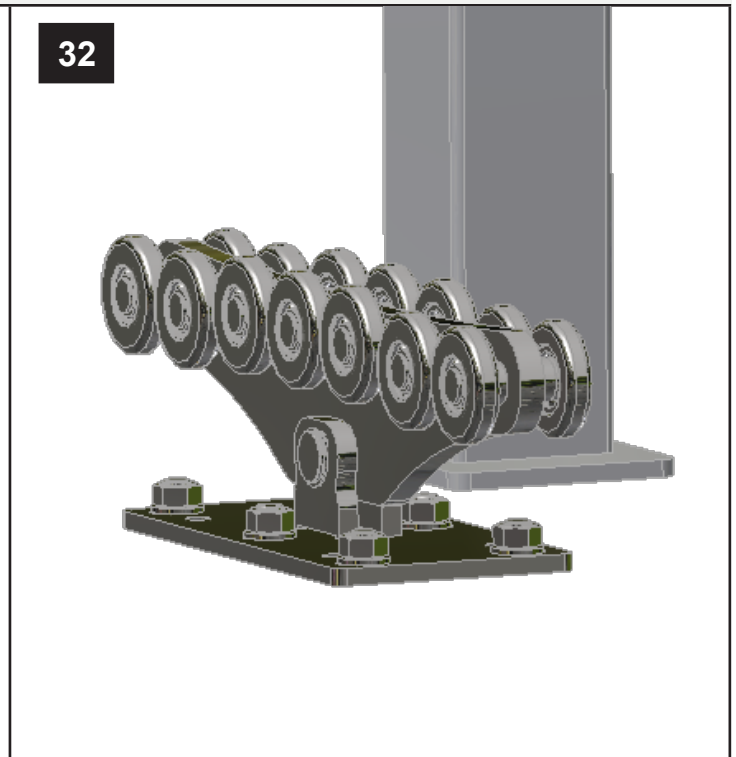
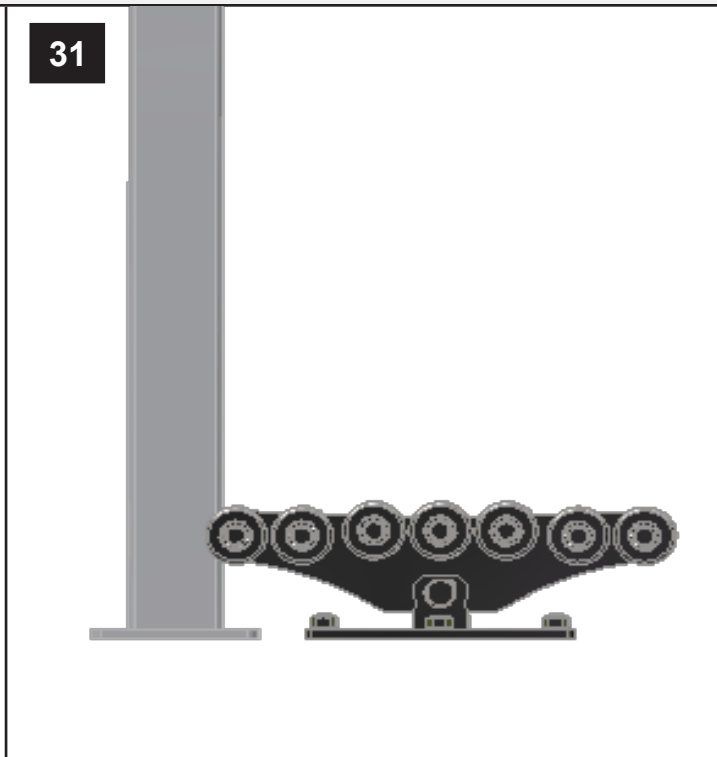
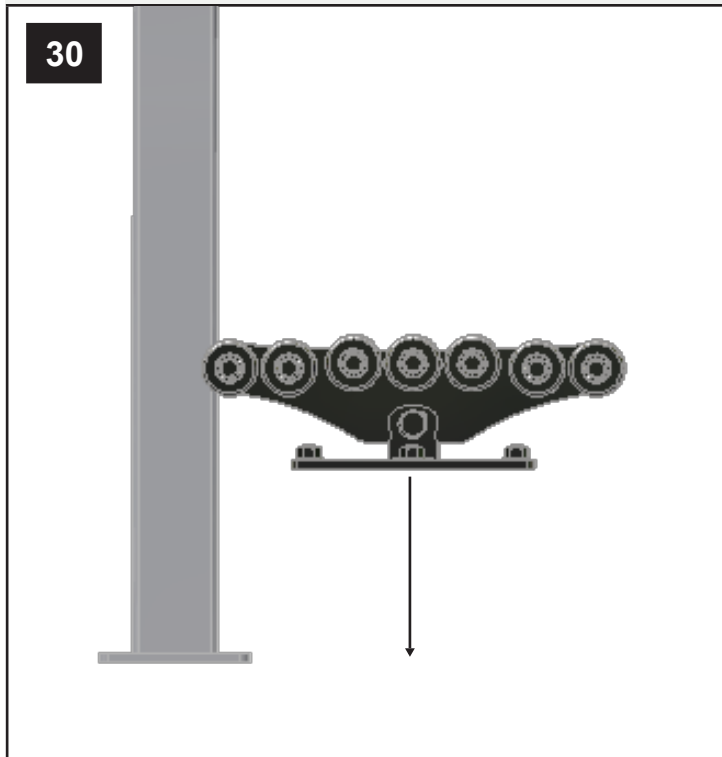

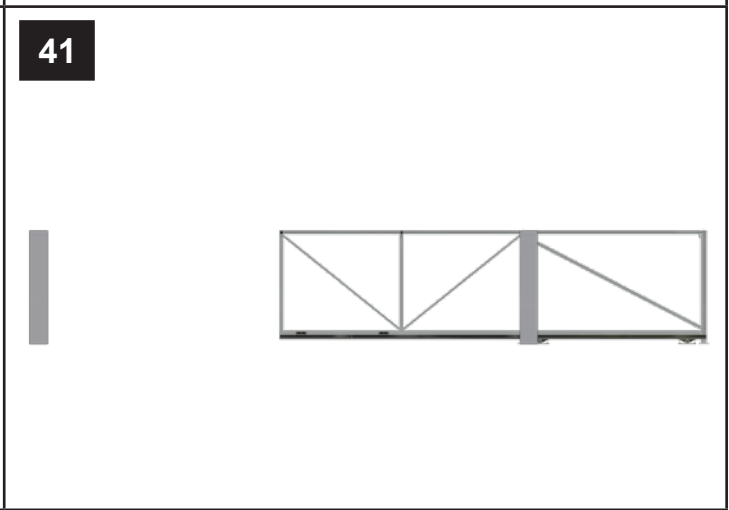
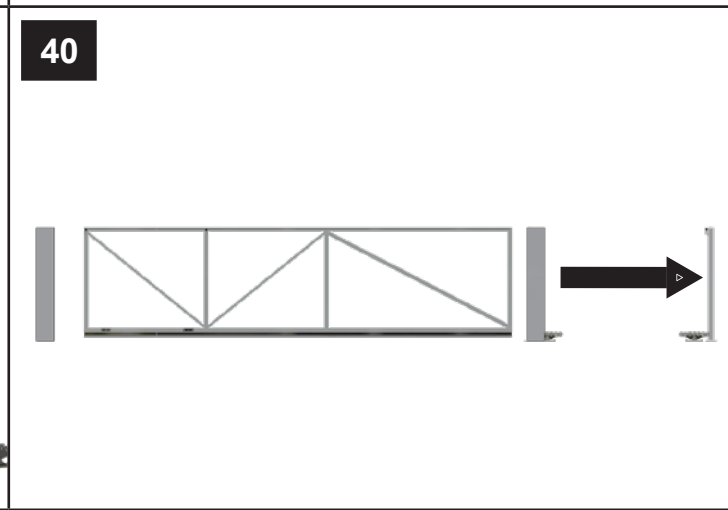
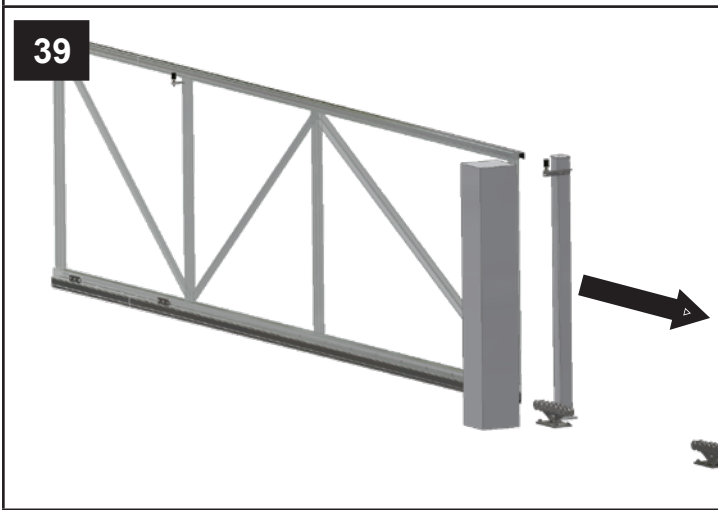
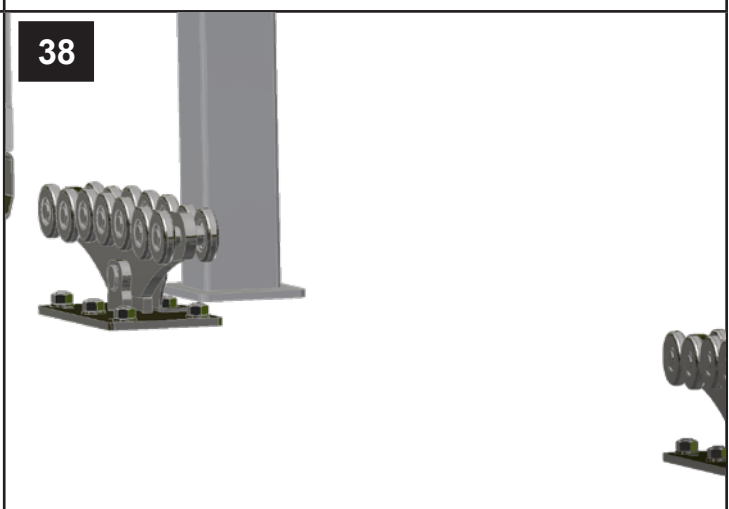
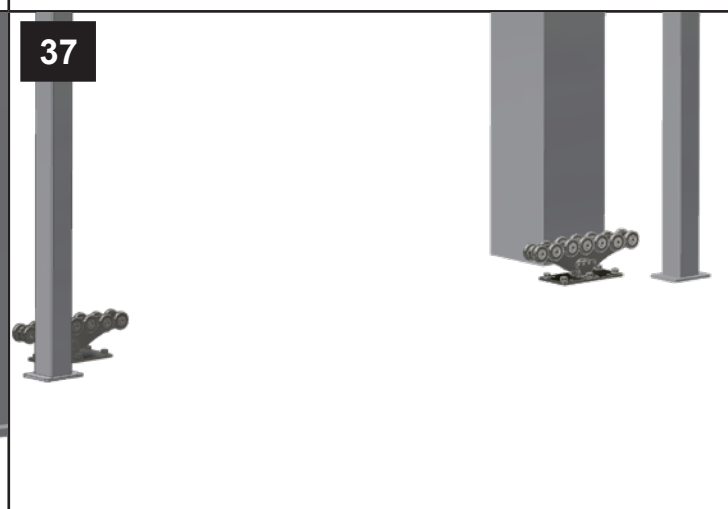
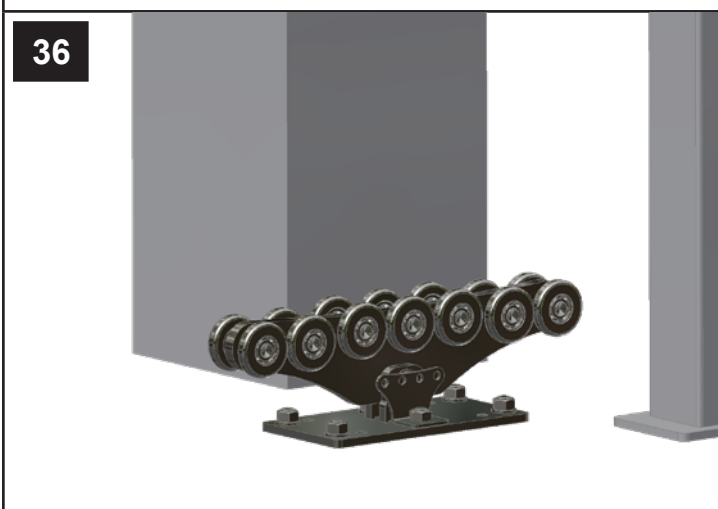
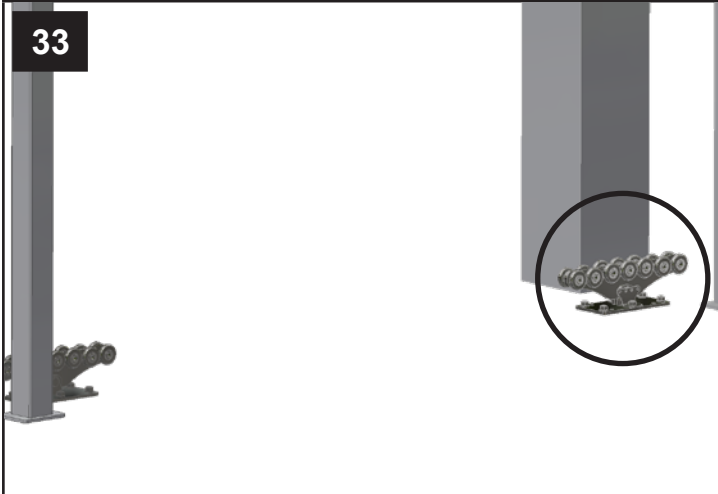

42

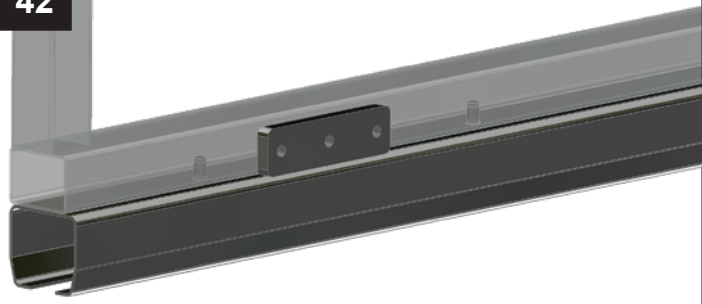

43

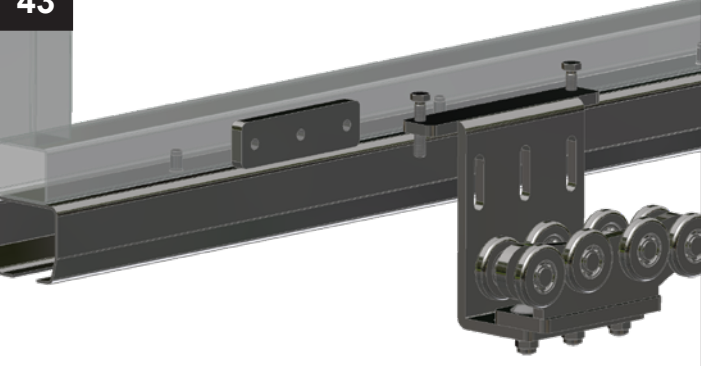

44

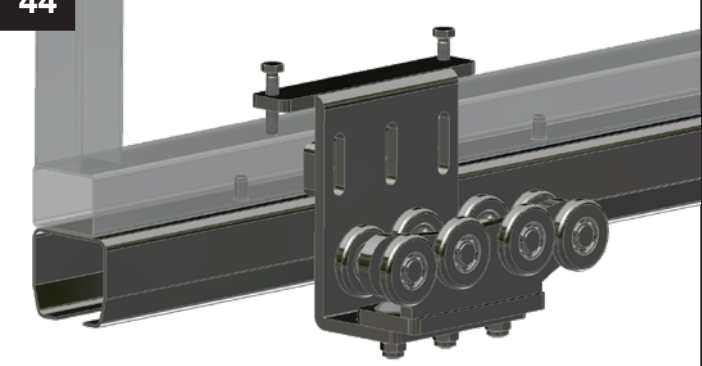

45

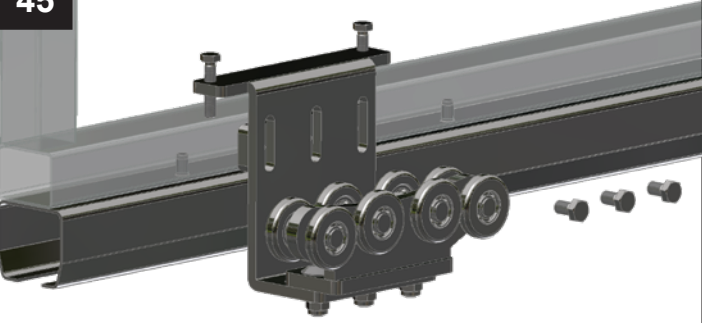

46

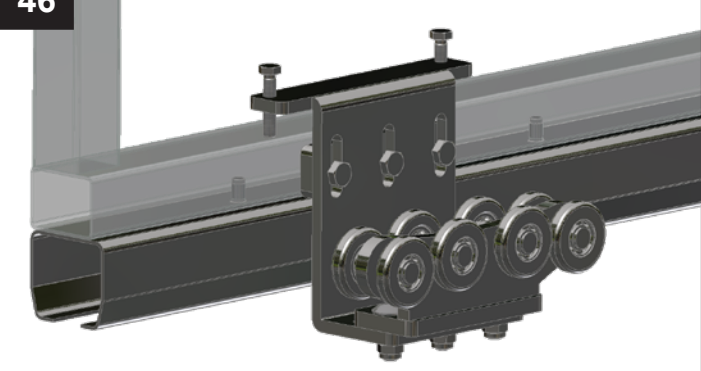

47



48

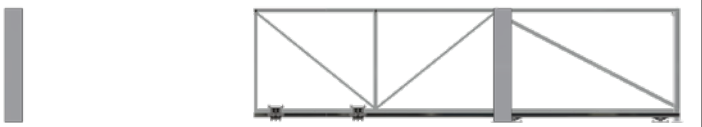

49

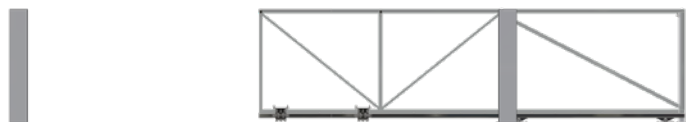

50

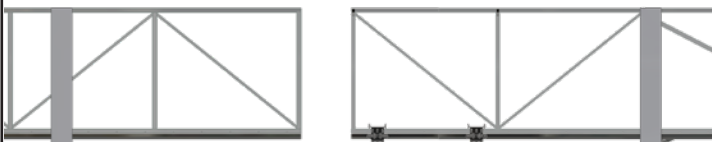

51



52



53

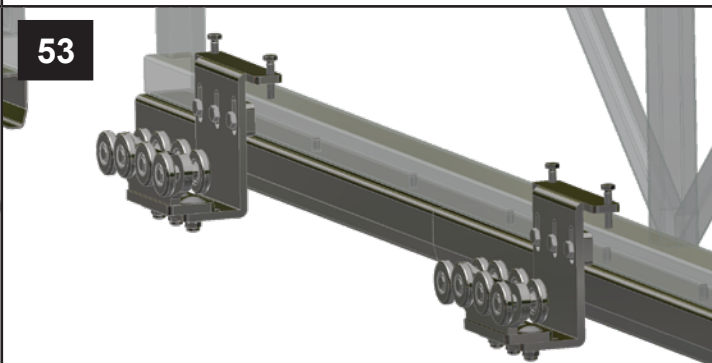

54





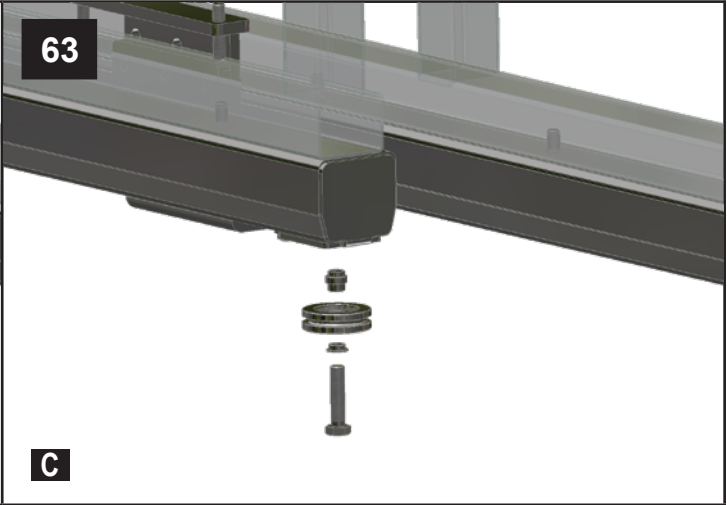
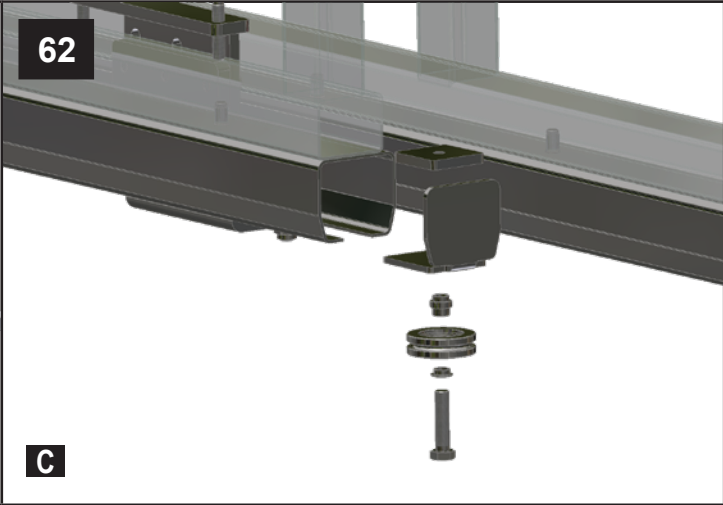
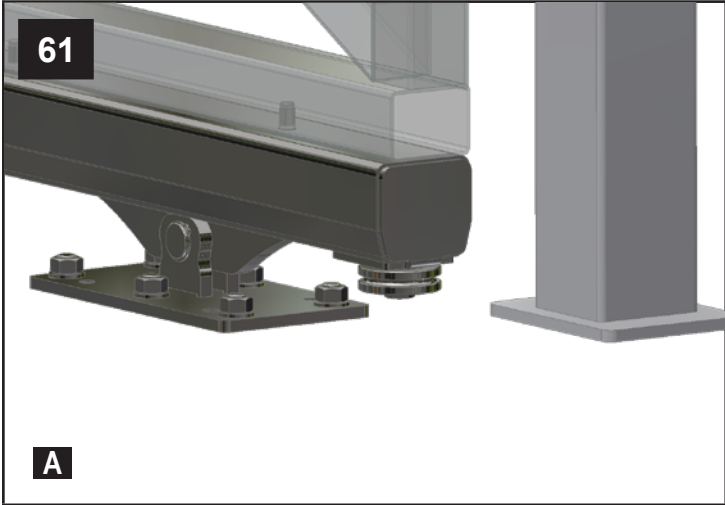
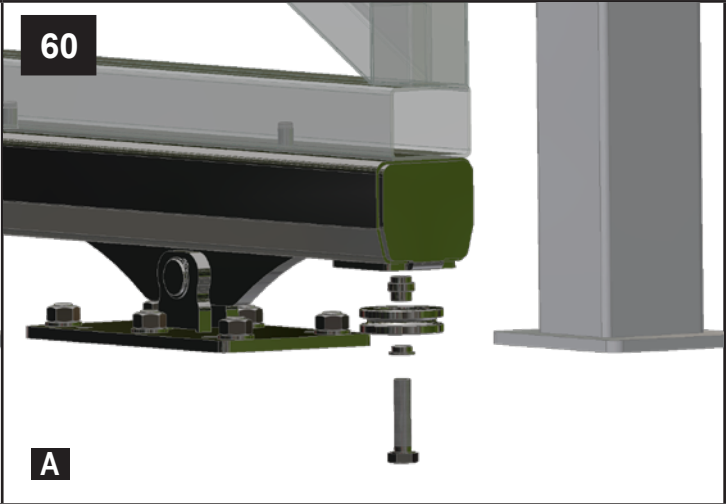
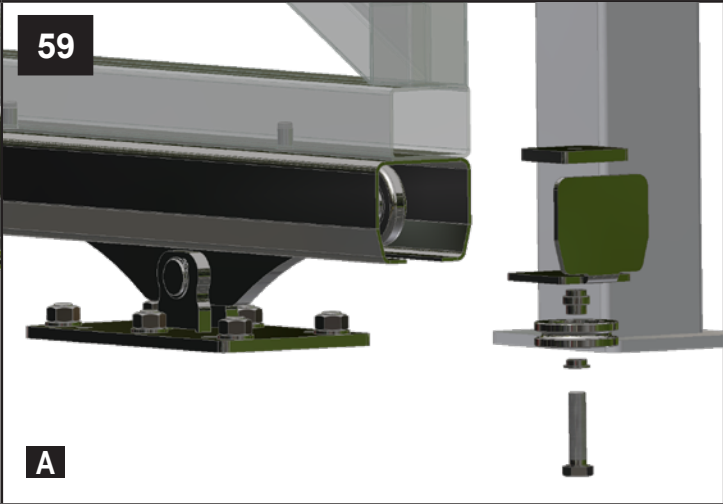
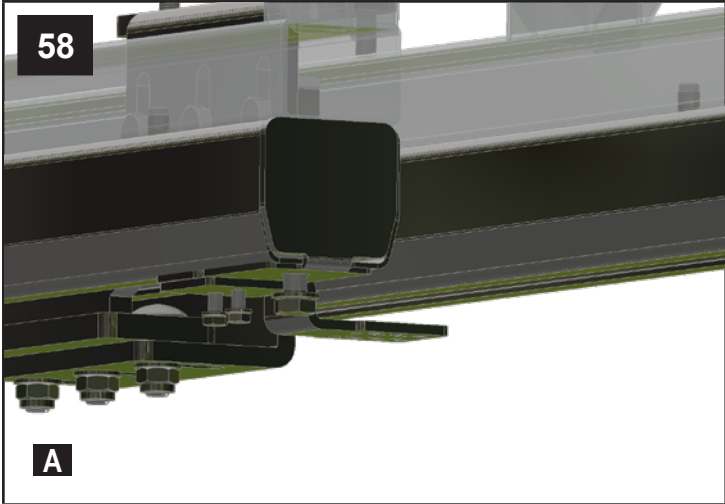
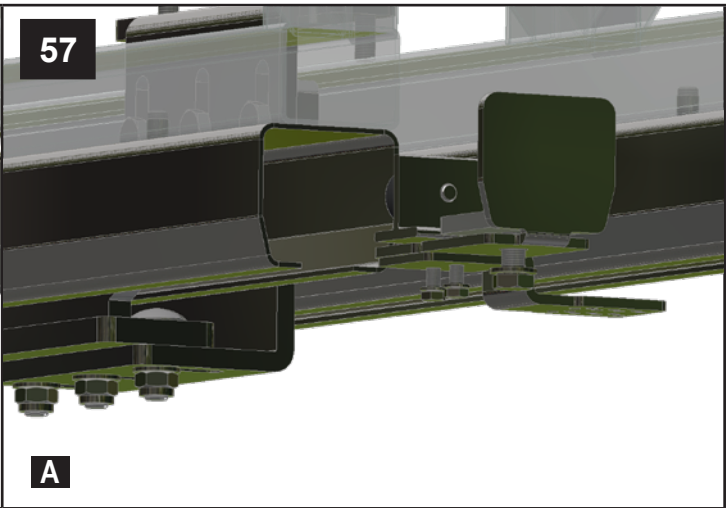
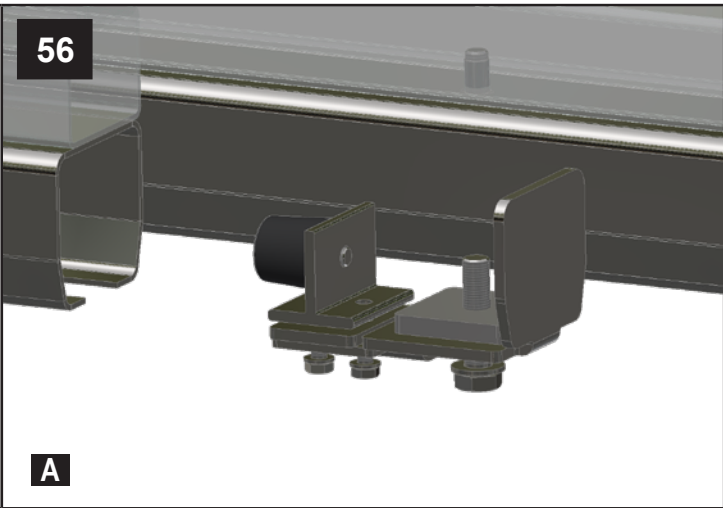
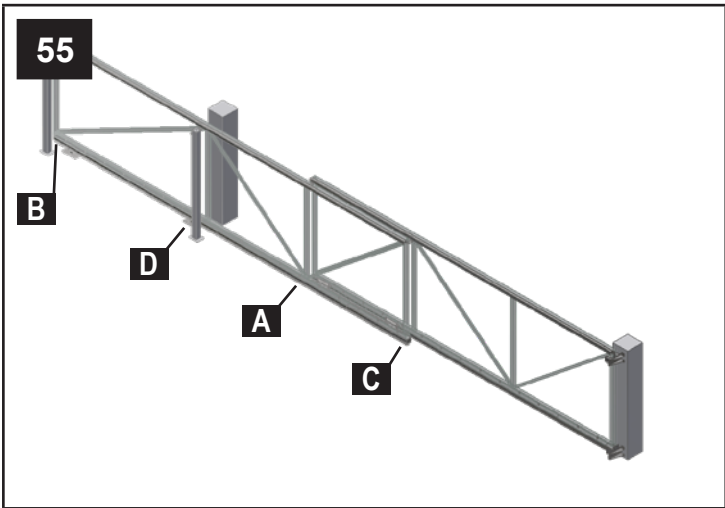



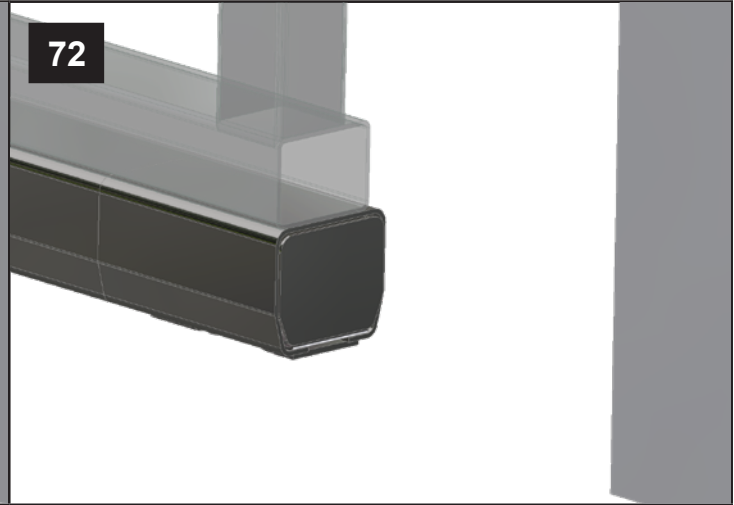
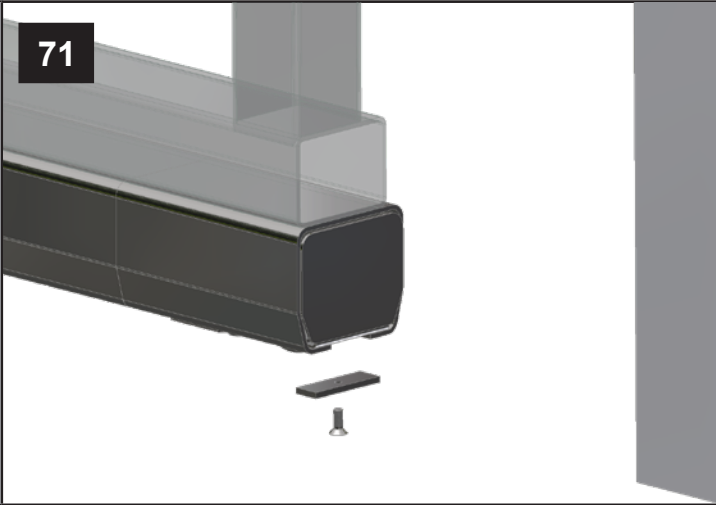
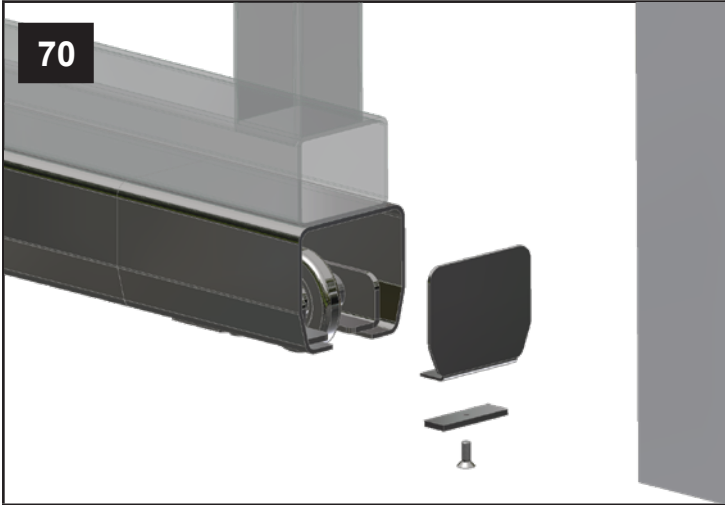
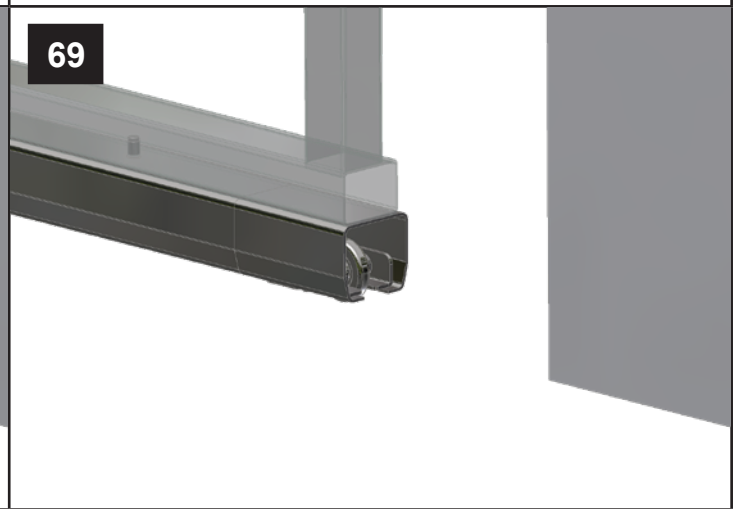
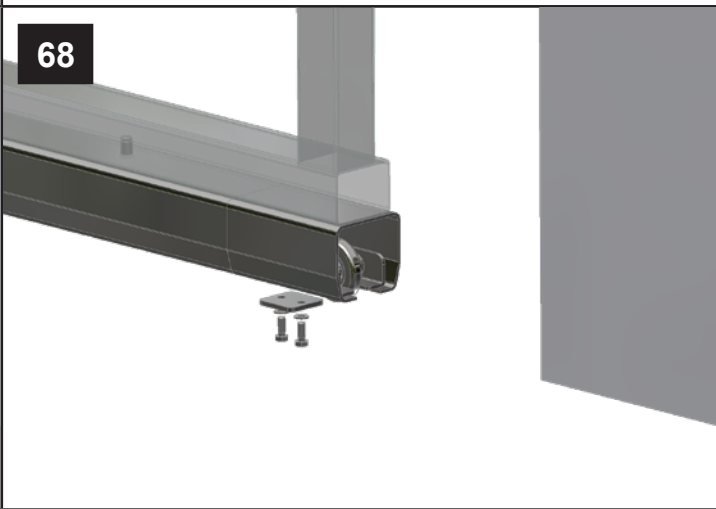
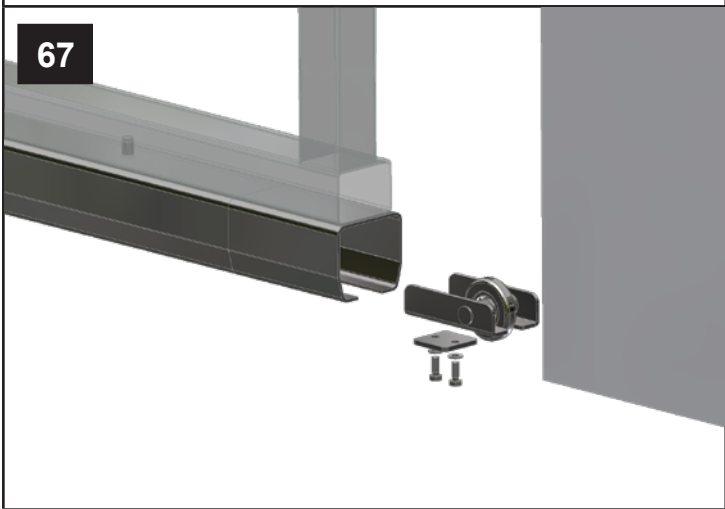
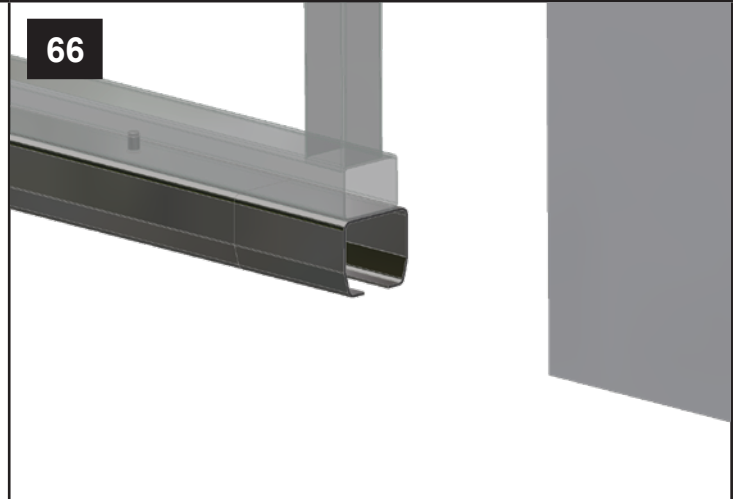
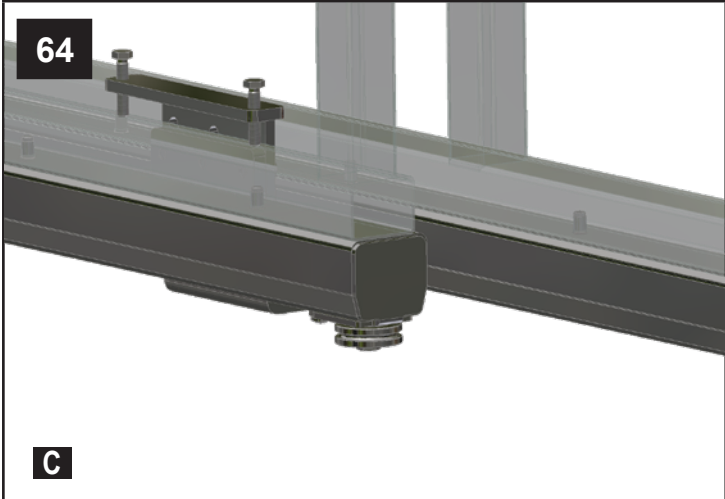

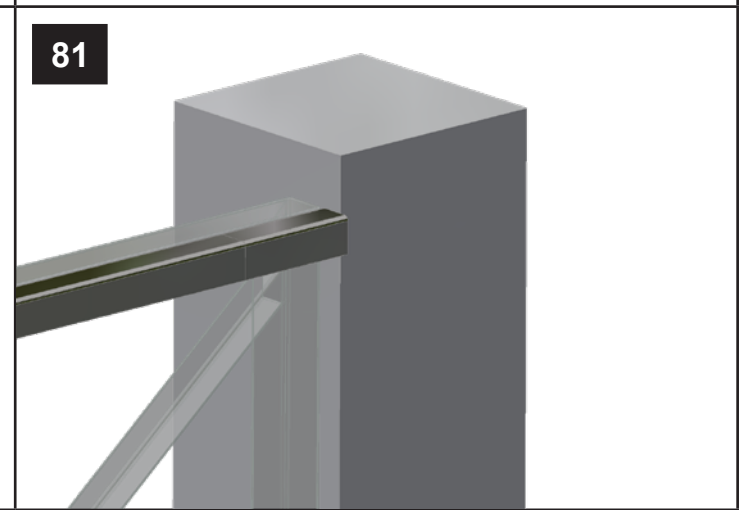
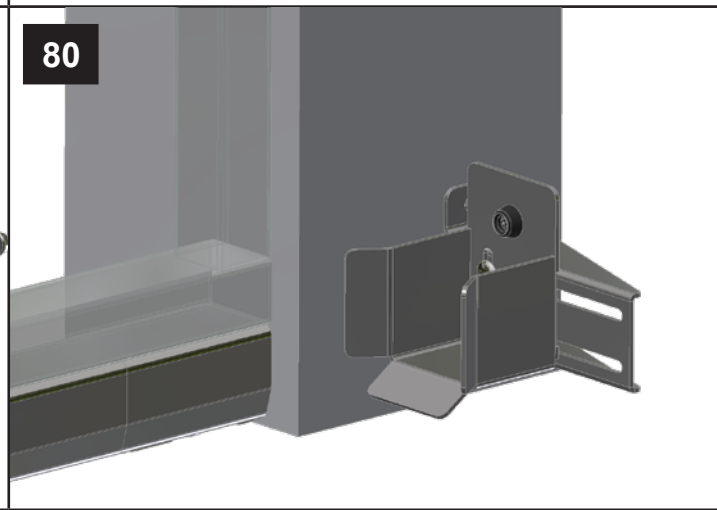
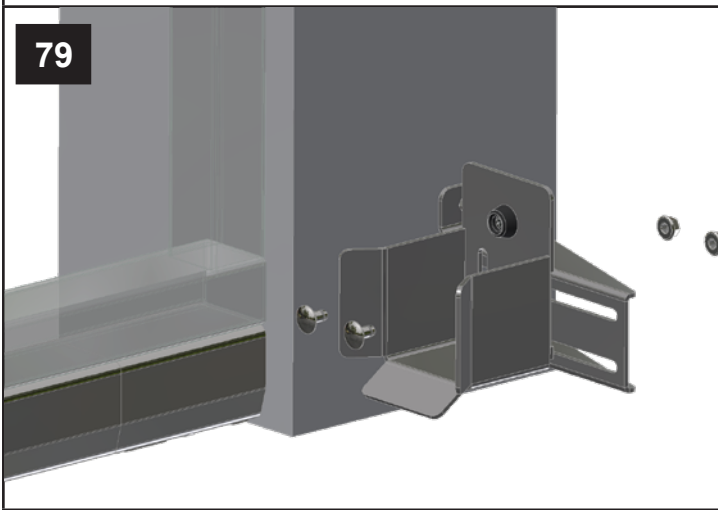
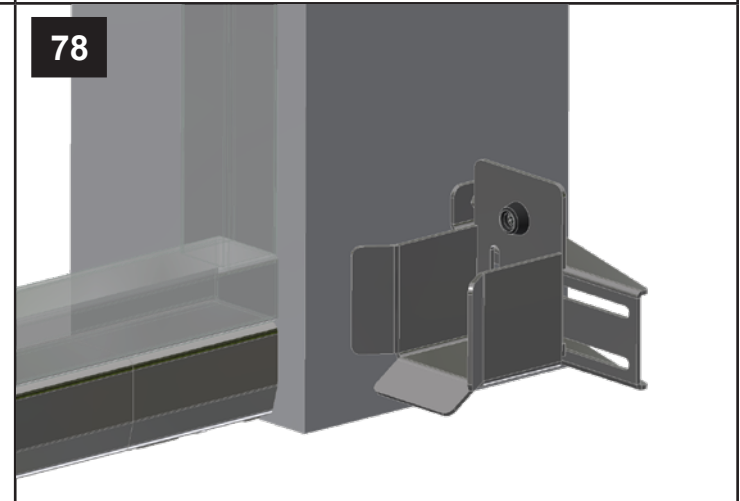
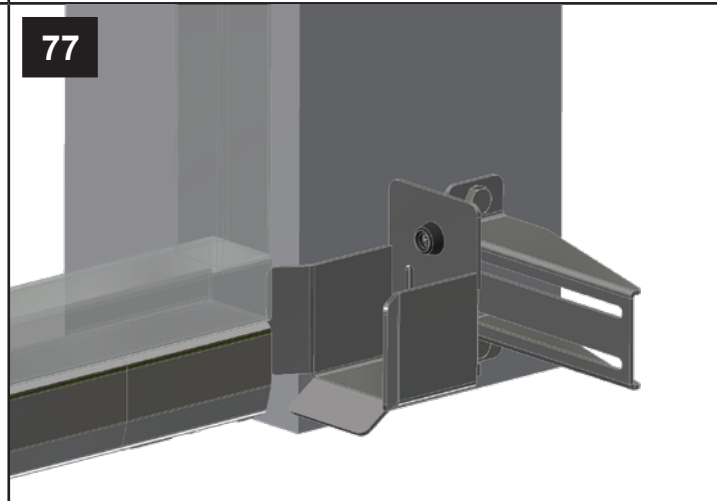
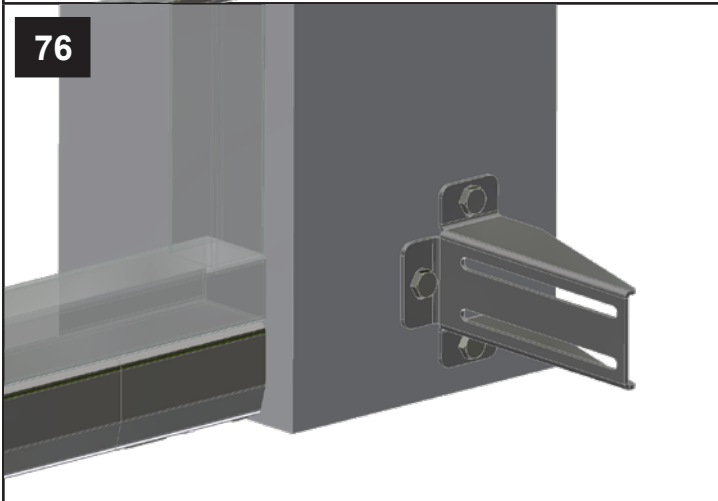
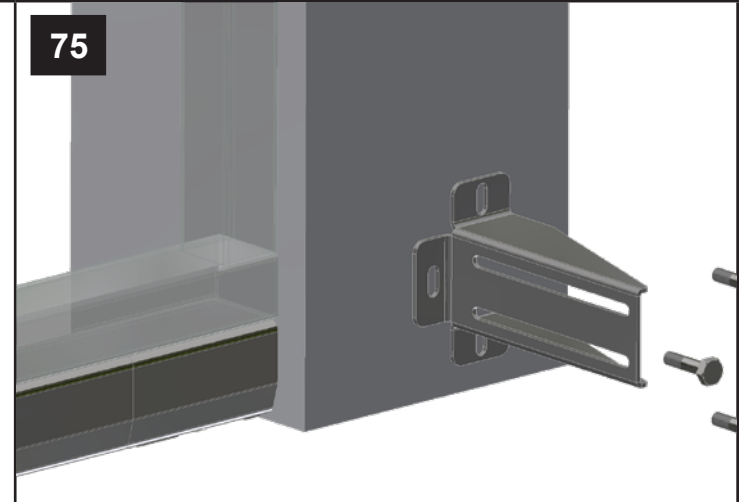
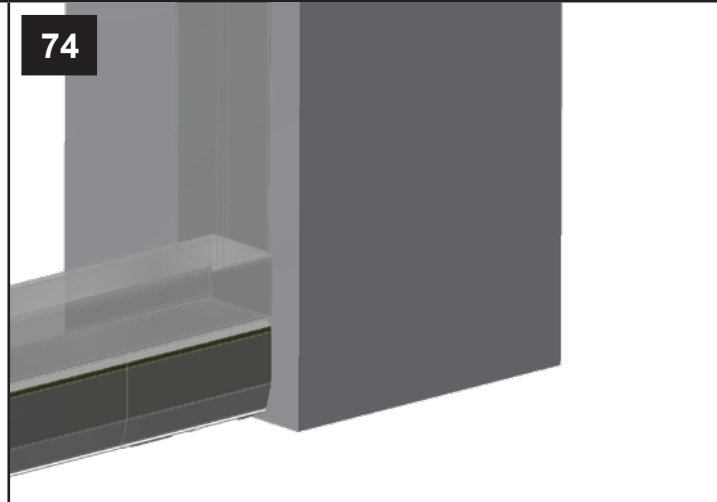

82

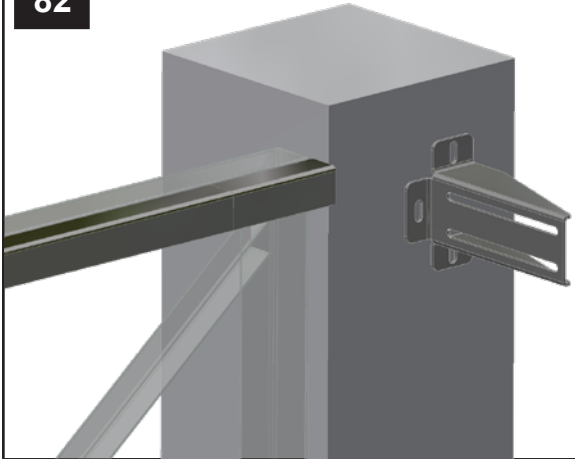

83

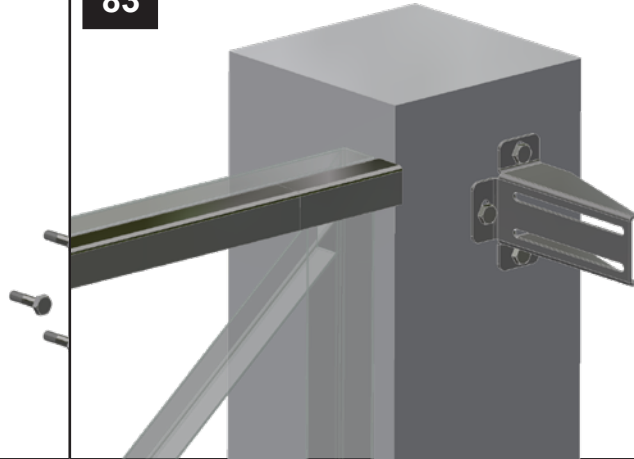

84



85

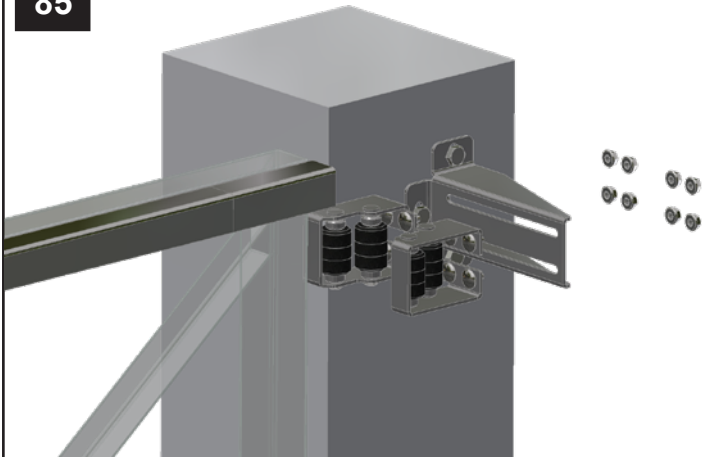

86

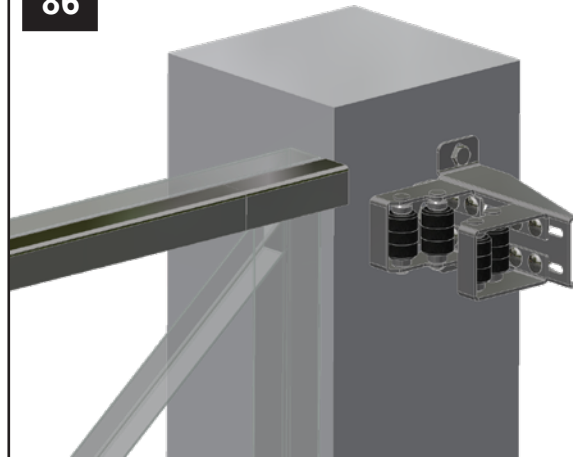

87

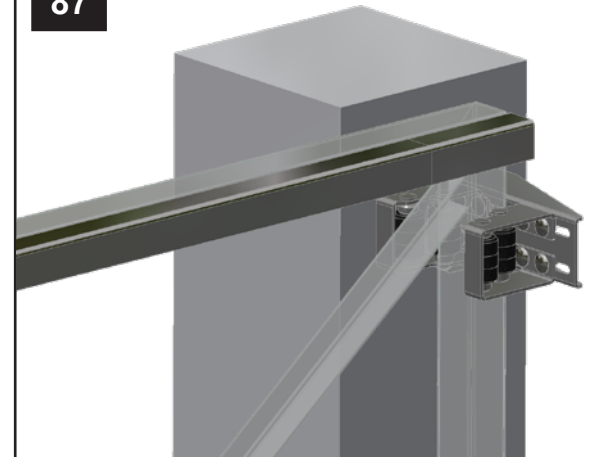

88

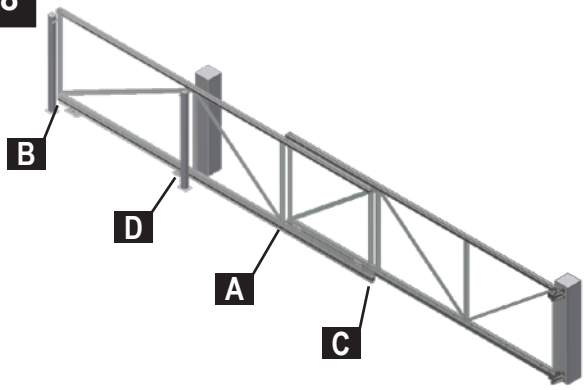

89

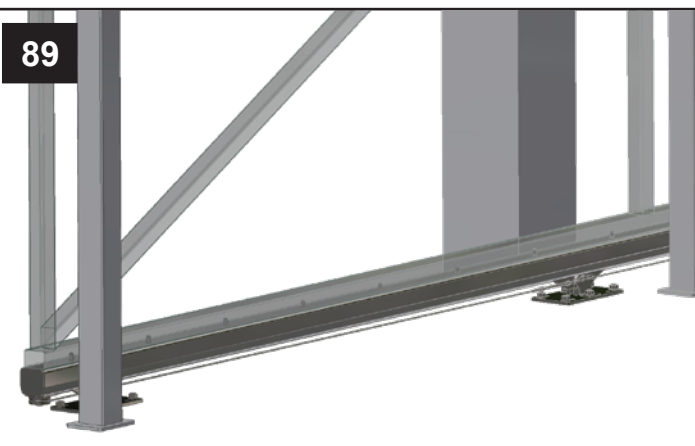

90

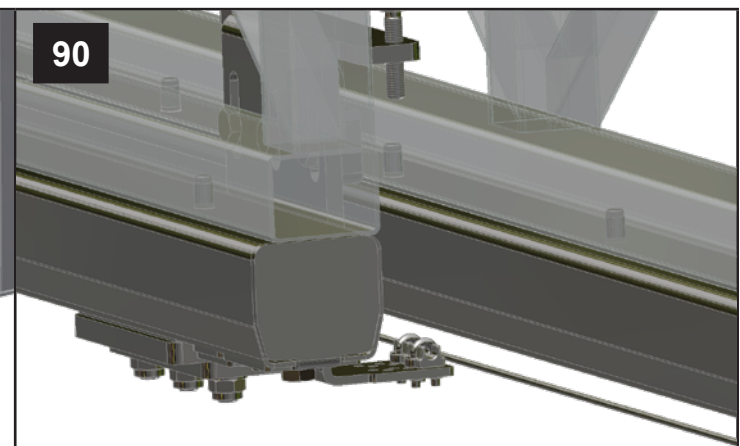

27

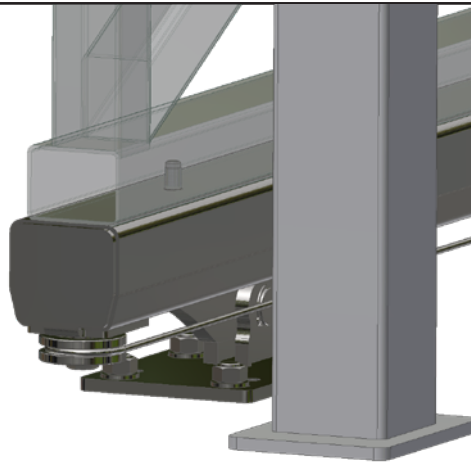

28

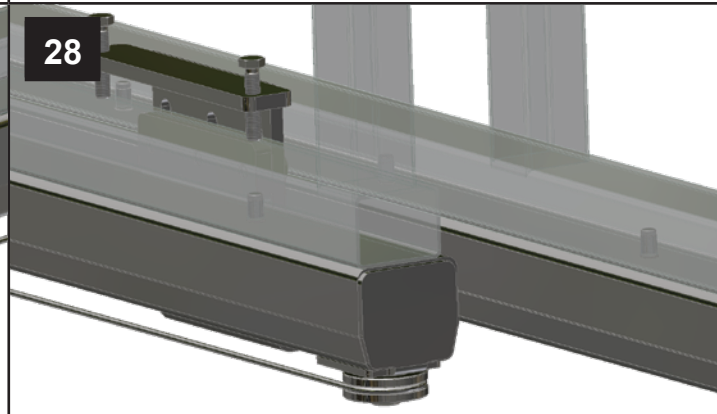

29

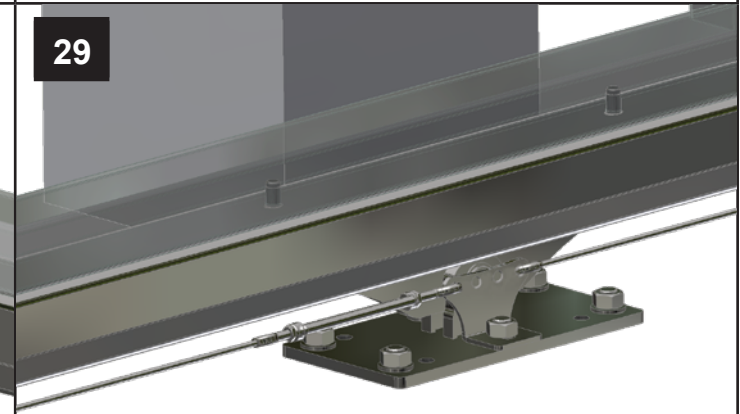

B

C

D

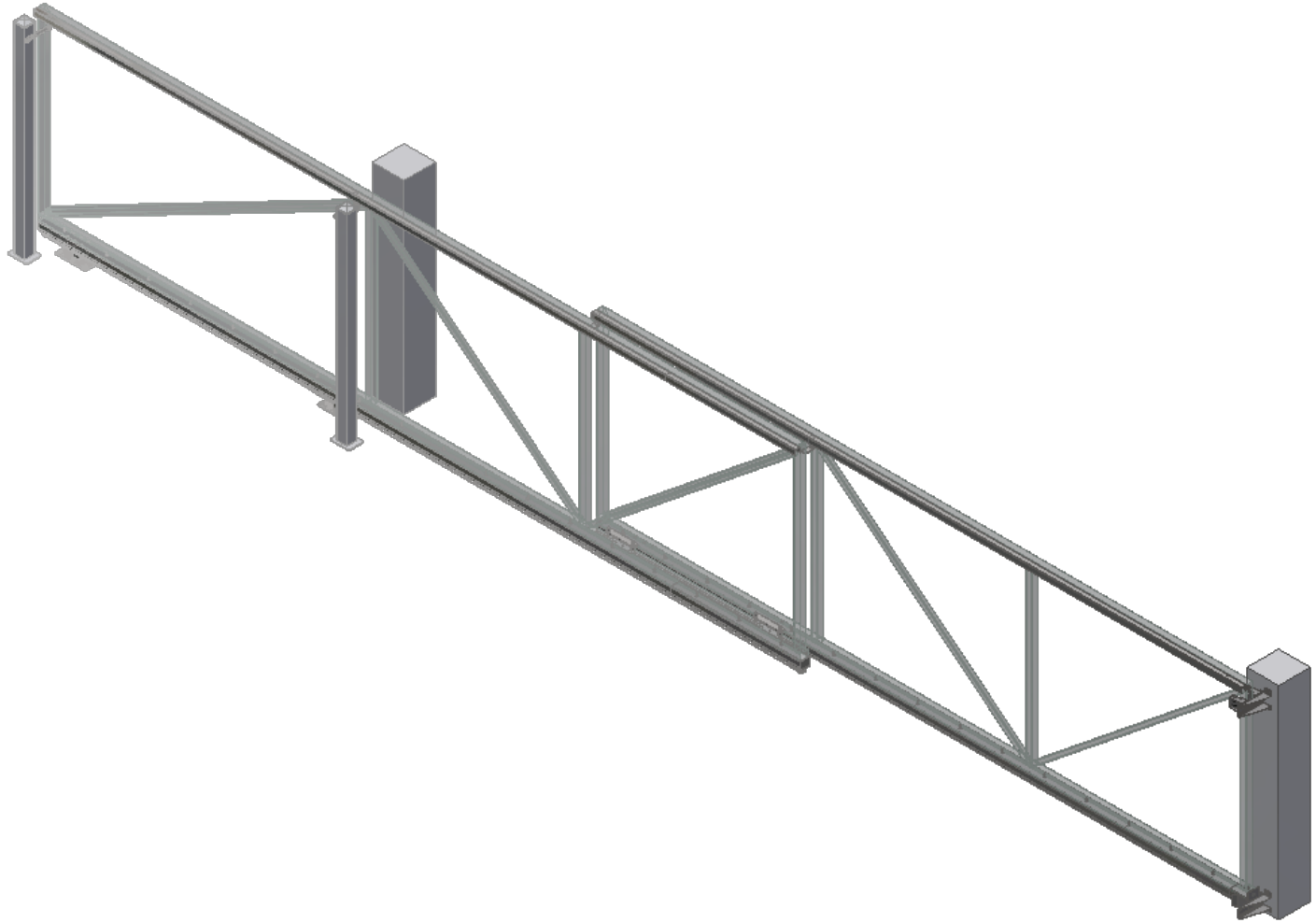
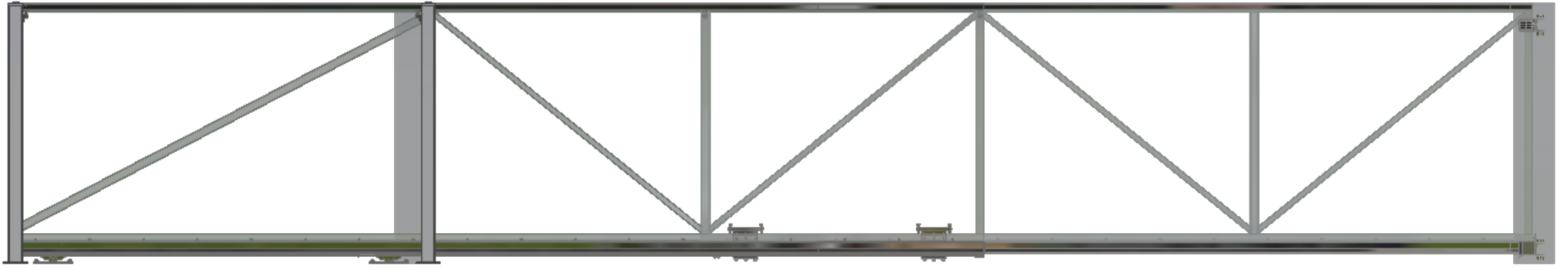

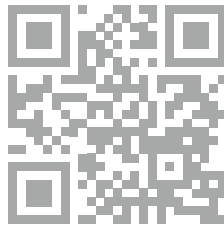

[www.cais.eu](http://www.cais.eu)